

INSTRUCTIONS FOR USE
PUMP

MODEL
P 52 EX

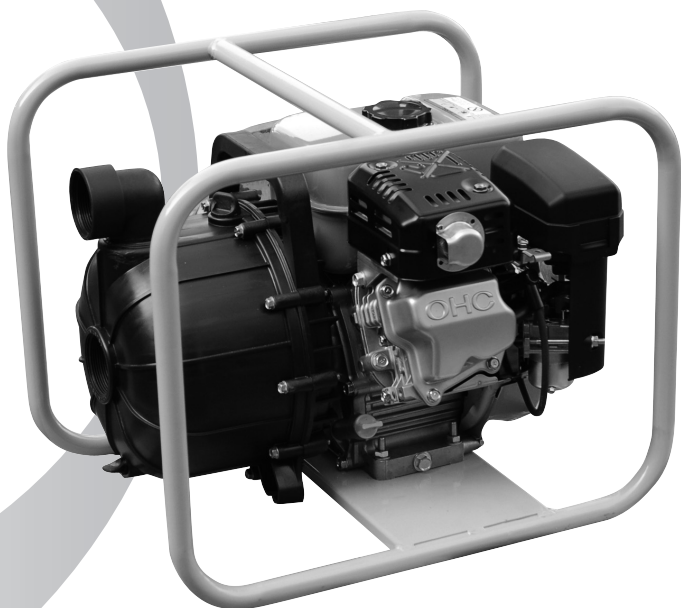

Thank you for purchasing a Worms Entreprises pump set powered by ROBIN SUBARU.

This manual covers operation and maintenance of the pump set.
Please read this manual carefully.

For any further information please contact our after sales service at:

WORMS ENTREPRISES S.A.S.
Parc Gustav Eiffel
1 Bd. de Strasbourg
Bussy St Georges
77607 MARNE LA VALLEE-FRANCE
Tél. +33 (0) 1 64 76 29 50
Fax +33 (0) 1 64 76 29 88

In the case of a problem with your pump set, please note the engine serial number and use it in any correspondence.

 **ATTENTION**

This pump is delivered without oil.

SUMMARY

1 - GENERAL PRESENTATION	PAGE 4
2 - SAFETY INSTRUCTIONS	PAGE 4
3 - SPECIFICATIONS.....	PAGE 6
4 - PREPARING THE PUMP FOR OPERATION.....	PAGE 7
5 - PUMP SET USE.....	PAGE 9
6 - MAINTENANCE SCHEDULE.....	PAGE 9
7 - MAINTENANCE GUIDE	PAGE 11
8 - TROUBLESHOOTING	PAGE 12
9 - PREPARATION FOR STORAGE.....	PAGE 13
10 - SPARE PARTS	PAGE 14

1. GENERAL PRESENTATION





The unit is made up of the following:

- A clear or fresh water centrifugal pump set powered with a Robin Subaru gasoline engine delivering 45 M³/h.
- The inlet and outlet ports are of a diameter of 2" BSP, delivered with couplings and strainer.





2. SAFETY INSTRUCTIONS

Make sure that you review each warning and respect all safety recommendations.

2-1. ENVIRONMENT



-  Use your pump set on a flat, stable base, free from gravel or grit.
-  Install your pump set at least 1 meter from any building.
-  Install your pump set far away from any inflammable product (waste material, lubrication liquid, explosive, ...)
-  **IN THE CASE OF FREEZING WEATHER CONDITIONS, MAKE SURE TO EMPTY THE PUMP CASING TO AVOID BEING FROZEN AND DAMAGING THE PUMP.**

2-2. FIRE PROTECTION

-  Stop the engine before filling the fuel tank.
-  Do not overfill the fuel tank and spill gasoline.
-  If the gasoline spills over, rapidly clean up the spilt gasoline and wait for the traces to be dried up before restarting the engine.
-  Never use the pump set while smoking or near a naked flame.



2-3. EXHAUST GAS PROTECTION

-  Never breath in the exhaust gas: it contains carbon monoxide which is odour and colourless and extremely dangerous for human health. In extreme conditions it can be fatal.
-  Never use your pump set inside a building or in a closed environment.
-  Be extremely careful when using the pump set close to other people.



2-4. OTHER SAFETY PRECAUTIONS

- ⚠ Never get too close to moving parts or hot parts of the engine or pump when it's running.
- ⚠ Never let someone run the pump set without proper understanding of the manual and safety instructions.
- ⚠ Start by familiarising yourself with emergency stopping procedure as well as all aspects of safety controls to be made on the pump set before starting the engine.
- ⚠ Correctly close the fuel tank cap before moving your pump set.
- ⚠ Check the engine oil level and top up if necessary before starting the engine.
- ⚠ Check the fuel lines for fuel leaks before starting the engine.



3. SPECIFICATIONS

P 52 EX	
Pump	
Type of Pump	Self priming
Suction Ø coupling	50 mm
Delivery Ø coupling	50 mm
Maximum flow	750 L/min - (45 m ³ /h)
Pressure	3,8 bars
Maximum total head	38 m
Maximum suction head	8 m
Solid size Ø	-
Mechanical seal	Carbone silicium
Engine	
Engine Model	EX 17
Engine Type	4 strokes gasoline
Fuel	Unlead gasoline
Fuel tank capacity	3,6 Liters
Capacité du réservoir d'huile	0,9 Liters
Dimensions LxIxH (mm)	520 x 400 x 425
Dry weight	24 kg

4. PREPARING THE PUMP FOR OPERATION

4-1. CONNECT THE SUCTION PIPE TO THE PUMP

Use the appropriate tools to make the connection.

ATTENTION

If the pump set is pumping water containing solids, it is necessary to use a strainer connected to the suction pipe. These foreign bodies can damage the pump if they are sucked into the pump casing.

4-2. CONNECTER THE DELIVERY HOSE TO THE PUMP

Use the appropriate tools to make the connection.

4-3. CHECK THE ENGINE OIL LEVEL

Place the pump set on a horizontal flat surface and fill the engine sump until you achieve the maximum level on the dipstick (approximately 0,6 litre).

- Use an engine oil with a viscosity de 10 W 30 for ambient temperature between -15°C to + 35°C
- If the conditions of use should exceed these limits, please contact WORMS ENTREPRISES concerning the correct type of oil to use.
- Oil of an inferior quality or a lack of oil can cause serious engine damage and reduce the expected engine life time.

ATTENTION

Use only engine oil designed for petrol engines.
Never use engine oil designed for diesel engines.
To check the correct oil level, simply position the dipstick in the tapped hole without screwing it into position.

4-4. FILLING THE ENGINE FUEL TANK

- Use unleaded automotive gasoline.
- The fuel should be new and free for foreign particles. The fuel should be transported in containers designed for unleaded automotive gasoline. If this is not the case, the

carburettor could become faulty, blocked with foreign bodies.

- The tank contains 3,6 litres.
- Wipe off any spilt fuel thoroughly.
- Always stop the engine before refilling the fuel tank.

4-5. FILLING THE PUMP BODY WITH WATER

Fill the pump body with water through the fill plug located on the top of the casing, before starting the engine.

ATTENTION

Do not run the pump dry; always fill the pump body with water before starting. Failing to do this will cause the pump to overheat. Using the pump dry will destroy the mechanical shaft seal. If the pump should run dry, the pump must be left to cool before filling with water in order to avoid a thermal shock which will damage the pump.

5. PUMP SET USE

5-1. STARTING

Place the engine speed control in the maximum position. Turn the engine switch to the on position. Pull the recoil starter gently, when the effort increase due to the compression, bring the recoil handle to its original position. Then pull the recoil starter swiftly to start the engine, once the engine starts, return the handle slowly to its original position.

5-2. COLD STARTING

As described above, with the choke in the start position.

5-3. RUNNING SPEED

Once the engine started, open progressively the choke, place the engine speed control in the minimum position and allow the pump to warm up for several minutes. Then increase the speed to achieve the desired output. To save fuel and increase the pump set life time, use the maximum engine speed only when necessary.

5-4. STOPPING THE ENGINE

Place the engine speed control lever in the minimum position and let the pump run for several minutes. Then turn the engine switch to the stop position and wait until the engine stops completely.

6. MAINTENANCE SCHEDULE

6-1. DAILY INSPECTION

Check the following points before using the pump set:

<input checked="" type="checkbox"/>	Fuel level in the tank
<input checked="" type="checkbox"/>	Abnormal vibration or noise
<input checked="" type="checkbox"/>	Abnormal exhaust gas (White, blue or black)
<input checked="" type="checkbox"/>	Clean air filter element
<input checked="" type="checkbox"/>	Safe environment
<input checked="" type="checkbox"/>	Correct and clean oil level
<input checked="" type="checkbox"/>	Oil or fuel leaks
<input checked="" type="checkbox"/>	Broken or missing nuts and bolts
<input checked="" type="checkbox"/>	Pump body filled with water

6-2. REGULAR INSPECTION

In order to maintain correct pump set performance it is necessary to follow the recommended maintenance schedule as below.

The schedule is based on a regular use of your pump set.



This indicates that special tools or skills are required. Consult your local dealer.

Every :	8 hours every day	100 h	300 h	500 h	1000 h
Check the fuel level	<input checked="" type="checkbox"/>				
Check that all nuts and bolts are correctly tightened	<input checked="" type="checkbox"/>				
Check the engine oil	<input checked="" type="checkbox"/> Top up the level every day				
Change the engine oil	<input checked="" type="checkbox"/>	<input checked="" type="checkbox"/>			
Clean the air filter element		<input checked="" type="checkbox"/>			
Open the pump body and clean the casing		<input checked="" type="checkbox"/>			
Check the valve clearance					
Clean the fuel strainer cup with unleaded automotive gasoline(remove the foreign bodies and water)			<input checked="" type="checkbox"/>		
Change the fuel strainer					<input checked="" type="checkbox"/>
Check the valve seats					

7. MAINTENANCE GUIDE

7-1. HOW TO CHANGE THE OIL

- First oil change after 25 hours.
- The following after 100 hours intervals.
 - When the engine is still hot, remove the drain plug. To increase the flow, remove the oil dipstick from its hole.
 - Replace the drain plug.
 - Fill the engine until the top mark on the dipstick is achieved.
- The engine life depends on the quality of the engine oil (See §4.3).

ATTENTION

Use only oil recommended for gasoline engines.
Do not screw the dipstick in position to check the oil level.

7-2. HOW TO CLEAN THE AIR FILTER

The air filter should always be clean. If not this will directly affect the engine performance, the engine will run badly.

- Every 100 hours, remove the primary element (mousse) and the secondary element (paper). Clean the mousse element with diesel fuel oil and let it dry. Change the paper element.
- When the pump set is used in dusty conditions, check the air filter every 30 or 50 hours and clean if necessary.

7-3. REMOVE WATER FROM THE FUEL STRAINER CUP

- Approximately every 300 hours, remove the water which has accumulated in the fuel strainer cup, and every 1000 hours change the filter by a new one.
- After this operation, purge the air in the fuel system.

7-4. CHECK THE NUTS, BOLTS ET SCREWS

- Tighten loose nuts and bolts.
- Check for fuel and oil leaks.
- Replace damaged parts by new ones.
- Remain aware of security hazards.

7-5. REPLACE FUEL PIPES

- Replace the fuel pipes every two years.
- If a pipe leaks, change it straight away.

8. TROUBLESHOOTING

NOTE : If you need to contact WORMS ENTREPRISES., remember to note the engine serial number and type.

8-1. THE PUMP DOES NOT TURN OVER:

Le moteur ne démarre pas (voir § 7-4)
La turbine est grippée : démonter et nettoyer.

8-2. THE FLOW IS LOW:

- The pump can be sucking in air: Check the connections are airtight.
- The engine is failing to run at correct speed: contact WORMS ENTREPRISES.
- The mechanical seal is broken: contact WORMS ENTREPRISES.
- To much suction head: reduce the suction head.
- In correct piping. Use suitable piping.
- Water leak in the circuit: repair the leak.
- The impeller is blocked by a foreign body: remove and clean.
- Worn impeller.
- The strainer is blocked: clean it.

8-3. THE PUMP DOES NOT SELF PRIME:

- The pump can be sucking in air: Check the connections are airtight.
- Insufficient quantity of water in the pump body: fill the pump body with water.
- The drain plug is leaking: Screw it up tightly.
- The engine is failing to run at correct speed: contact WORMS ENTREPRISES.
- Air is entering the pump via the mechanical seal: contact WORMS ENTREPRISES.

8-4. THE ENGINE DOES NOT START:

Make the following checks.

IS THE FUEL TANK FULL?

- Check the fuel level.
- Check that the engine speed control lever is in the maximum position.
- Check that the fuel cock is open. Purge the fuel system.
- Pull the recoil starter and check that the fuel flows correctly, contact WORMS ENTREPRISES.

DOES THE FUEL CONTAIN FOREIGN MATERIAL?

- Drain the fuel tank and check that no solid material, water or other foreign substance is mixed with the fuel.

9. PREPARATION FOR STORAGE

9-1. DRAIN THE WATER FROM THE PUMP

- Remove the drain plug.

ATTENTION

Clean the tapped hole before replacing the drain plug to avoid damaging the thread.

9-2. DRAIN THE FUEL

The procedure is as follows:

- Remove the fuel strainer cup.
- Turn the fuel cock to the open position.
- Open the fuel tank cap and collect the fuel in an appropriate container.

9-3. OIL THE ENGINE

- Change the used oil, by new oil.
- Remove the cylinder head cover and oil the rocker arms and the valves.
- Turn over the engine 2 or 3 times and replace the cylinder head cover.

9-4. CLEAN AND STORE

- Pull the recoil starter until reaching the compression, stop and leave in this position.
- Clean the engine thoroughly with an oiled cloth, cover the engine, and then store in a dry well ventilated area.

10. SPARE PARTS

EXPLODED VIEW

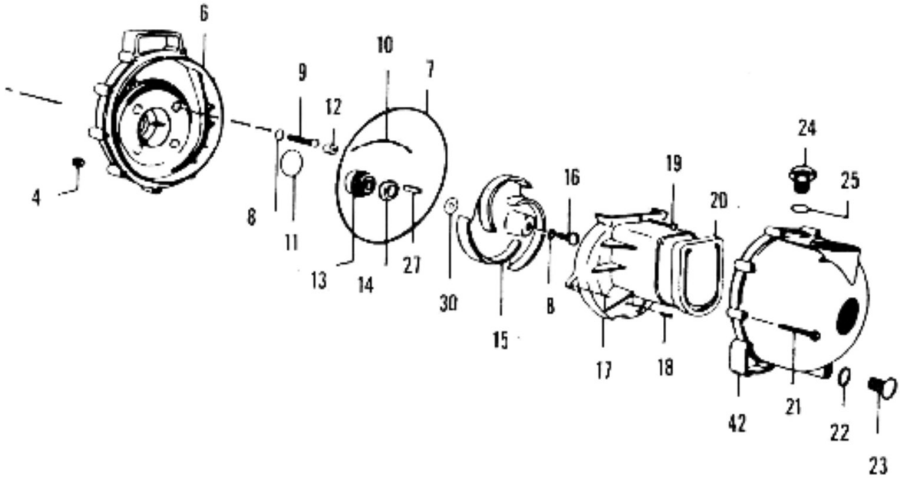

	Kit pompe complet EPDM/POLYEST	P-58-15U4
15	Impeller	P58-0704-30
20	Check valve EPDM	P58-0705-72
11;13;14	Shaft seal EPDM	P58-0714-12
8	O ring EPDM	P58-0717-72
7	O ring EPDM	P58-0719-72
4	Stainless steel nut	P58-0721-10
24	Plug	P58-0722-30B
23	Drain plug	P58-0723-30
18	Screw for Volute	P58-0725-10
10	O ring EPDM	P58-0754-72
25	O ring EPDM	P58-0765-72
30	Shim 0.015M/M	P58-0778-11
30	Shim 0,038M/M	P58-0778-12
30	Shim 0,0762MM	P58-0778-13
11	O ring EPDM	P58-0976-72
22	O ring for drain plug EPDM	P58-1009-72

MU_P52EX_GB

MU-P52EX-GB

V28032011FR

WORMS
ENTREPRISES

Head Office

Parc Gustave Eiffel - 1 Bd. de Strasbourg - Bussy Saint Georges - 77607 Marne la Vallée - Cedex 3 - FRANCE

Standard

TEL. +33 (0) 1 64 76 29 50

FAX +33 (0) 1 64 76 29 99

Commercial service

TEL. +33 (0) 1 64 76 29 60

FAX +33 (0) 1 64 76 29 99

After sales service

TEL. +33 (0) 1 64 76 29 80

FAX +33 (0) 1 64 76 29 88